

MatriX | 1050/500 III

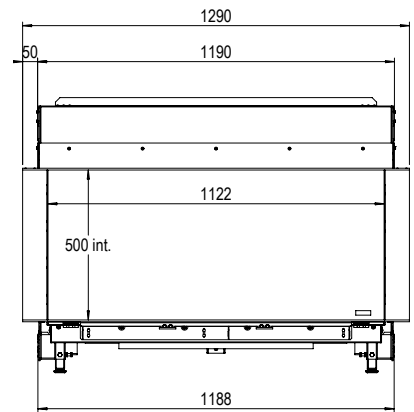
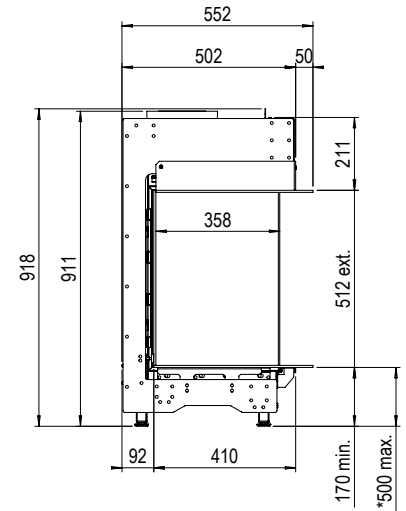
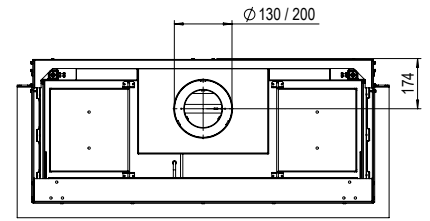

ENERG
енергия · ενεργεια

Faber MatriX 1050/500 I, II, III

A++
A+
A
B
C
D
E
F
G

8,1
kW

ENERGIA · ЕНЕРГИЯ · ΕΝΕΡΓΕΙΑ · ENERGIA · ENERGY · ENERGIE · ENERGI

2015/1186

Specifications

MatriX 1050/500 III

Type	Built-in
Model	Three-sided model
Exterior dimensions WxHxD in mm	1290 x 918 x 552
Fire display WxHxD in mm	1122 x 500 x 358
System	Log Burner 2.0®
Decoration	Log set
Back walls	Smooth steel
Remote	ITC remote
Power (kW)	8,1
Operating system	Honeywell
Energy label	B

OPTIONS

- Glass back wall black
- Anti-reflective glass
- Symbio Module
- Wall bracket
- Adjustable legs

Depth frame 100mm will be available again in 2021. Faber will inform you when the frame becomes available in due course.

There is **so much to tell...**

For more information, please take a look at the website

www.faberfires.com